

English

**intelbras**

---

User guide

**IVP 8000 EX**



## **IVP 8000 EX** **Infrared passive sensor**

Congratulations, you have just purchased a product with Intelbras quality and security.

The IVP 8000 EX sensor has dust, water protection<sup>1</sup> white light immunity, making it perfect for the harshest environments, and can be installed indoors, semi-open or outdoors. Its lens is specially built for long life, containing materials resistant to sunlight.

The presence of the digital accelerometer ensures that the position of the sensor is not changed after installation, avoiding sabotage in the security system.

The sensor also has an integrated temperature sensor, to offer the same detection sensitivity and reliability in different environments (from - 10 °C to + 50 °C), low energy consumption circuit, providing a long battery life, communication status on the sensor via LED, low battery indication, tamper switch for tamper protection and Articulated support<sup>2</sup>, in order to guarantee the best detection angle in the most diverse environments. The IVP 8000 EX sensor is suitable for environments with the presence of pets up to 30 kg. Read the product introductory information carefully for the correct use of the sensor.

<sup>1</sup> Read item 2. Features of this manual.

<sup>2</sup> Read item 11. Articulated bracket of this manual

## Care and security



The sensor is compatible with AMT 8000 control panel versions 1.2.1 or higher.

- » LGPD - General Law for the Protection of Personal Data: Intelbras does not access, transfer, capture, or perform any other type of treatment of personal data from this product.
- » Follow all instructions in the manual for assembling and installing the product;
- » Fix the sensor on stable surfaces, where there is no flickering;
- » Do not use the sensor in areas with sudden changes in temperature, such as near air conditioners and heaters, fans, refrigerators and ovens. Do not expose the sensor to direct or reflected sunlight;

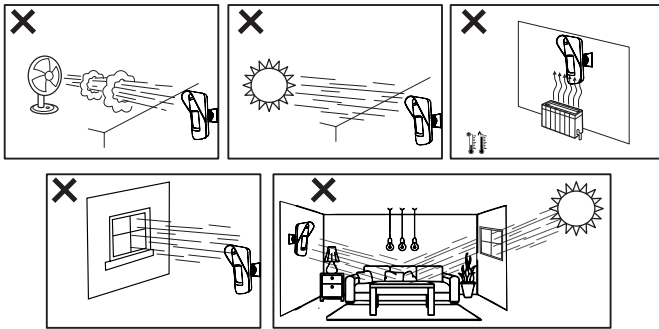

- » Wireless communication technology, when exposed to environments with high power irradiation, may suffer interference and have its performance degraded. Example: locations near TV towers, AM/FM radio stations, amateur radio stations, routers, etc.;
- » Do not touch the surface of the infrared (PIR) sensor. If necessary, use a soft cloth for cleaning;
- » The recommended installation height varies from 2 m to 2.2 m depending on the installation environment.
- » Do not place objects in front of the sensor. Keep the detection area clear of moving objects such as bushes, clotheslines, cars or any objects that block scanning. Do not exceed the installation height of the sensor (2.2 m).

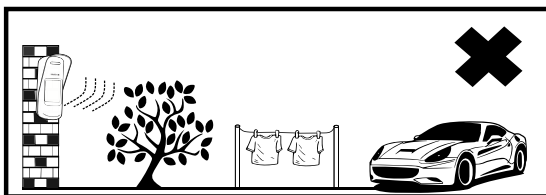

- » The sensor must be installed where a possible intruder is easily detected, that is, where a person makes the greatest possible movement across the detection beams when entering the environment (see the figure below);

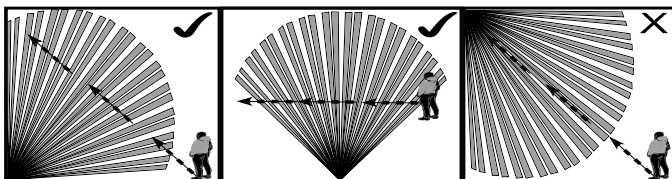

» It is important to note that the Pet function is designed for low-growing animals weighing up to 30kg. If the animal is on top of a bench, for example, the Pet function can be canceled.

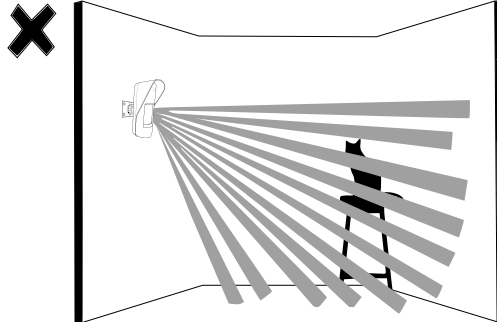

**Obs.:** before starting the installation, it is necessary to define the height at which the sensor will be positioned, which can vary from 2 to 2.2 m. If the sensor is installed at a height of less than 2.0 m or is tilted downwards, the Pet function will be compromised.

### 1.1. Scan

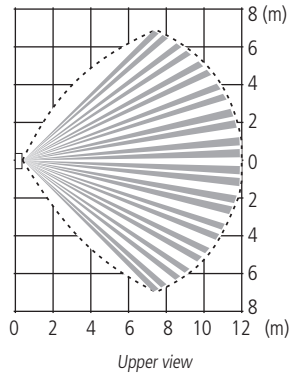

### 1.2. Detection range

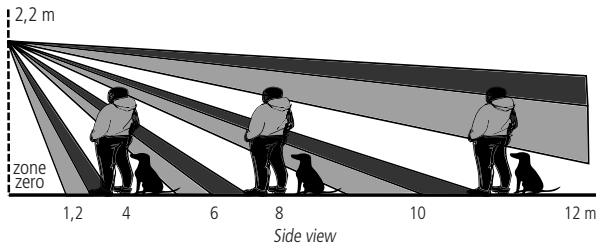

# Summary

1. Technical specifications	6
2. Features	6
3. Product	6
4. Sensor opening	7
5. Registering the IVP 8000 EX sensor	7
5.1. Deleting the sensor register	7
6. Identifying the best place for installation	8
7. Installation	8
7.1. Anti-Sabotage Function	8
8. Configuring the IVP 8000 EX sensor	9
8.1. Configuring the sensor through the keyboard	9
8.2. Disable Anti-Sabotage function <sup>1</sup>	9
8.3. Information on sensor settings	9
8.4. Information on LED operation and operating mode	9
8.5. Configuring the sensor through the application	10
9. Battery	11
10. Homologation	11
11. Articulated bracket	11
11.1. Care and security	11
11.2. Technical specifications	11
11.3. Product	12
11.4. Features	12
11.5. Installation with IVP 8000 EX base with internal nut housing	13
11.6. Installation with the base of the IVP 8000 EX without drilling	14
Warranty term	17

# 1. Technical specifications

Operating voltage	3 Vdc
Operating current	20 µA
Frequency band	915 MHz to 928 MHz
Modulation	DSSS BPSK 40 Kbps
Maximum transmission power	11 dBm
Battery	LITHIUM CR123A 3 V
Angle of detection	110°
Detection range	12 m
Method of detection	Double PIR
Animal immunity	Up to 30 Kg
Startup time	60 seconds
Operating temperature	-10 °C ~ +50 °C
RF Range	600 meters without barrier

## 2. Features

- » IPX4 protection against water and dust.
- » Position anti-sabotage (accelerometer);
- » Communication status check via LED;
- » Wireless communication with range of up to 600 meters with direct open field view;
- » Supervised wireless communication;
- » Encrypted transmission;
- » Micro controlled sensor;
- » Sensor operation adjustment through the AMT Remote Mobile application;
- » Inmunidad a los animales rastreros que pesen menos de 30 kg;
- » White light immunity up to 20,000 lux;
- » High RFI/EMI immunity;
- » Antimanipulación (tecla de manipulación);
- » Easy installation.

## 3. Product

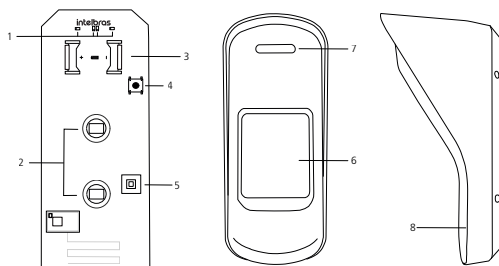

1. LEDs
2. PIR sensor
3. Battery connector
4. Synchronism button
5. Tamper key
6. Fresnel lens
7. LED light conductor
8. Product base

## 4. Sensor opening

To access the 8000 EX IVP board for registering, changing batteries or to unregister it from the center unit, simply remove the screw from the bottom with the help of a Philips wrench and remove its front cover. This way the board is exposed and ready to be handled. See the picture:

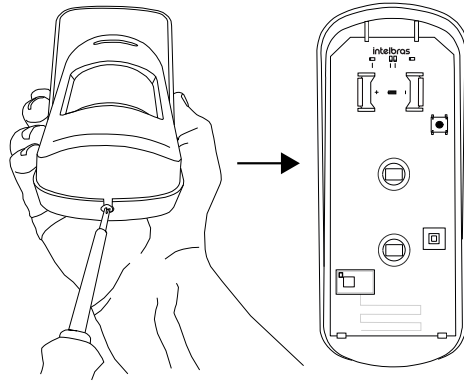

## 5. Registering the IVP 8000 EX sensor

To register the IVP 8000 EX sensor code in the AMT 8000 alarm center follow the procedure below:

1. Insert the battery of LITHIUM 3 Vcc - CR 123 A. The sensor will flash the blue LED for a few seconds (stabilization time), register the code of the IVP 8000 EX sensor in the AMT 8000 alarm center as follows:

Press the synchronization key of the AMT 8000 alarm center (the blue LED will be on) then press the synchronization button of the sensor observing if the LED located on the front of it will flash green indicating the correct register. If the LED flashes red, the registration has not been performed and the procedure must be repeated.

**Note:** after pressing the synchronization button of the alarm center, the blue LED indicating the center unit will remain on for approximately 3 minutes after the last registration made, after this time it will turn off automatically and it will not be possible to make new registrations until the synchronization key is pressed again. If no device is registered, the LED indicating the center unit will go off automatically after 3 minutes.

The sensors will be addressed according to the sequence performed, Example: The first sensor will be registered in zone 1, the second sensor in zone 2, the third sensor in zone 3 and so on.

To register other sensors through keyboard commands and more information, please check the complete manual of the AMT 8000 center.

### 5.1. Deleting the sensor register

If you want to delete the sensor registration, just press and hold the sensor synchronization key for approximately 10 seconds, watching the LED indicator until it flashes red twice.

**Note:** when physically erasing sensors, they must be erased from the control unit's memory via programming.

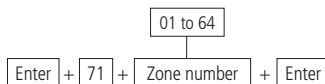

## 6. Identifying the best place for installation

The IVP 8000 EX sensor has communication signal level indications with the AMT 8000 center, this will help you choose the best installation location. Follow the procedure:

1. Once properly registered, take the sensor to the environment you wish to protect;
2. Check the position where the sensor can cover the whole environment, respecting the installation height, according to the table in item 1.2. *Detection range*.
3. Once chosen, position the sensor in the exact place where it will be installed and perform a transmission through a detection or tamper opening;
4. Observe the color that the LED will light up and check in the following table if the sensor can be installed in this location;

LED status	Communication level
Green	Excellent signal level (Recommended installation location)
Orange	Regular signal level Not recommended location for installation (communication failure may occur)
Red	No communication (Do not install on site)
Blue	Intrusion detection

5. If the signal level is not excellent, reposition the sensor and perform the procedure again.

## 7. Installation

Once the best installation location has been identified, set the height of the sensor.

We recommend that this sensor be installed at a height of 1.8 m to 2.2 m and positioned so that the intruder performs movements transverse to the sensor's detection radius. It is not recommended to install the sensor tilted up or down as this may impair the functioning of its PET function.

Check that the sensor is firmly fixed and not subject to flicker, in order to avoid unwanted triggering. The Articulated Bracket can be used to ensure greater flexibility to the installation, adapting to most scenarios and installation angles. Follow all the mounting instructions in the manual for maximum benefit.

### 7.1. Anti-Sabotage Function

This function consists of monitoring undue changes in the sensor's installation angle, ensuring that the sensor is not disabled if its installation position is changed, thus making the alarm system even safer.

After registering the sensor in the center unit, press the synchronism key for the sensor to activate the Anti-Sabotage function. During the first 2 minutes, the sensor will not trigger the tamper in order to adjust the final installation position. After the initial 2 minutes, the sensor will go into the test mode, where for 15 minutes the sensor will trigger from the tamper in the zone in which it was registered whenever its position changes, and then automatically restore this trigger. After the 15 minutes test period, the sensor will trigger the tamper only if there is a change in its installation position, with any horizontal or vertical inclination, but it will only restore the tamper if the synchronism switch is pressed.

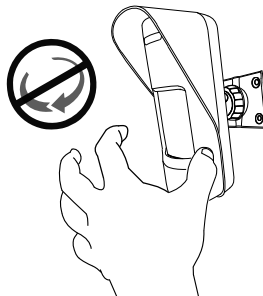



# 8. Configuring the IVP 8000 EX sensor

The sensor settings can be adjusted in two ways, below we present the step by step of each one.

## 8.1. Configuring the sensor through the keyboard

Using the keyboard of the AMT 8000 alarm center, go into the programming mode with the installer password, then type the following command:

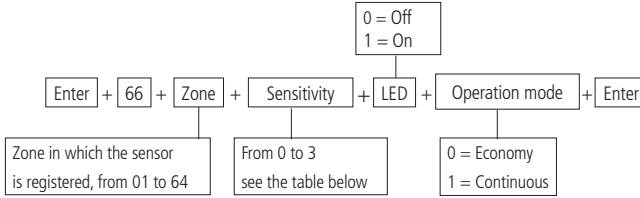

**Note:** on the EX 8000 IVP, the Operation Mode will not influence its operation.

## 8.2. Disable Anti-Sabotage function<sup>1</sup>



G - Group of zones from 0 to 6

After entering the command, using the keyboard keys, select which zone you want to disable the Anti-Sabotage function and press the *Enter* key to confirm.

<sup>1</sup> Available from version 2.0.0 of the sensor and version 2.0.0 of the AMT 8000 control panel.

## 8.3. Information on sensor settings

Sensitivity adjustment table.

Level	Condition
0	Minimum sensitivity
1	Normal sensitivity (factory default)
2	Intermediate sensitivity
3	Maximum sensitivity

Sensitivity adjustment table

## 8.4. Information on LED operation and operating mode

### LED

- » **Off:** with the LED Off option marked, the sensor will only light the LED for the first 15 minutes after battery insertion. Factory default.
- » **On:** with the LED function On, the battery life can be drastically reduced.

### Operation mode

With the center unit activated, the sensor transmits all the detections that have occurred to the alarm center, and the LEDs can also be turned on depending on the sensor configuration (default: Turned on). With the center unit deactivated, the sensor detects no presence and does not turn on the LEDs. In the initial 15 minutes after inserting the battery, the sensor turns on the LEDs with each detection, regardless of whether the center unit is activated or deactivated.

To test the sensor's operation with the center unit deactivated, simply enter the Test Mode menu or the wireless sensor Test function (check the center unit's manual) and wait for the first transmission, which can take up to 2 minutes.

## 8.5. Configuring the sensor through the application

1. After the application is properly connected to the alarm center, select Configure center on the main screen of the APP;

Menu	
Configure Center	>
Online	>
Events	>

2. After that, select sensors;

Settings	
General	>
Zones	>
Passwords	>
Communication	>
Event codes	>
IP monitoring	>
Ethernet/Wi-Fi	>
GPRS	>
Programed activation/deactivation	>
Sensors	>

Once you have done this, select the sensor you wish to configure, for example:

Sensor 1

Sensors	
Sensor 1	>
Sensor 2	>
Sensor 3	>
Sensor 4	>
Sensor 5	>
Sensor 6	>
Sensor 7	>
Sensor 8	>
Sensor 9	>
...Sensor 64	>

After selecting the sensor, the following adjustment screen will open.

Sensor 1	
<b>Sensitivity</b>	
Level 0 (minimum sensitivity)	<input checked="" type="radio"/>
Level 1 (normal sensitivity, factory default)	<input type="radio"/>
Level 2 (intermediate sensitivity)	<input type="radio"/>
Level 3 (maximum sensitivity)	<input type="radio"/>
<b>LED</b>	
Always Off	<input checked="" type="radio"/>
On when triggered	<input type="radio"/>

Modo de operação	
Economy mode	<input checked="" type="radio"/>
Continuous mode	<input type="radio"/>
Discard changes	Save

**Note:** for configuring the settings, check the sensitivity table, the explanations of LED operation and the Operation mode in item 9.2. Information on the sensor settings.

## 9. Battery

Use only quality batteries with the correct sizing for the device, and with the typical use of the device, the battery life forecast is 3 to 5 years and can be influenced by the number of triggering, weather conditions and configuration mode.

The battery model should be CR123A 3 V, being used one (1) battery per sensor.

## 10. Homologation



05326-18-00160

This equipment is not entitled to protection against harmful interference and may not cause interference to duly authorized systems. This is a product approved by Anatel, the approval number can be found on the product label, for queries, visit the website: [sistemas.anatel.gov.br/sch](http://sistemas.anatel.gov.br/sch).

## 11. Articulated bracket

The articulated bracket was built to fit perfectly in most of the presence sensors available in the market, besides having a large steering angle, support for wiring passage and UV protection for indoor or outdoor installation.

### 11.1. Care and security

- » Follow all instructions in the manual for product assembly and installation.
- » Make sure that both the sensor and the bracket are securely attached to the installation site to avoid changes in the detection angle of the product.
- » Make sure the installation site is stable and not subject to flicker.

### 11.2. Technical specifications

General characteristics	
Material	Plastic with UV protection
Weight	44 g
Load capacity	1.5 Kg
Installation environment	Indoors / outdoors
Dimensions (W × H × D)	99 × 58 × 64
Horizontal movement angle	160°
Vertical movement angle	160°

### 11.3. Product

Mounted support

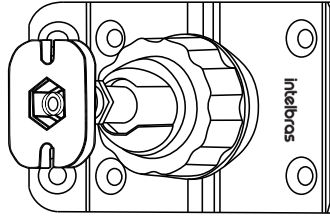

#### Components

1	Axis
2	Cover
3	Ring
4	Base
5	Nut
6	Connector
7	Screw 3.5 x 9.5 mm

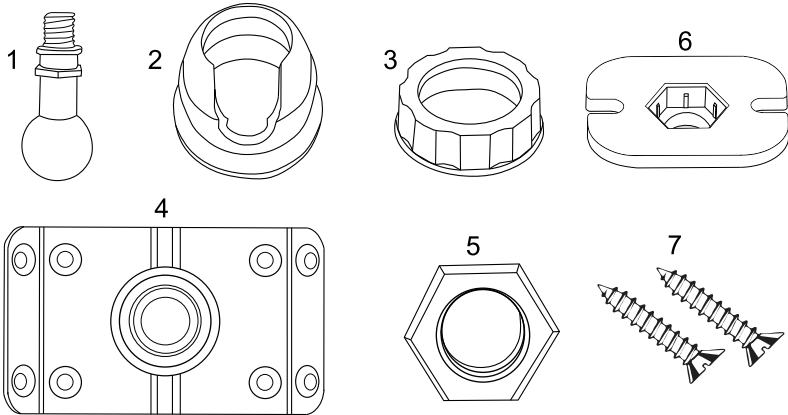

### 11.4. Features

- » Built in UV-protected material;
- » Easy installation;
- » Wide application scenario;
- » Discreet and robust.

### 11.5. Installation with IVP 8000 EX base with internal nut housing

» Insert the shaft into the cover (piece 1 and piece 2);

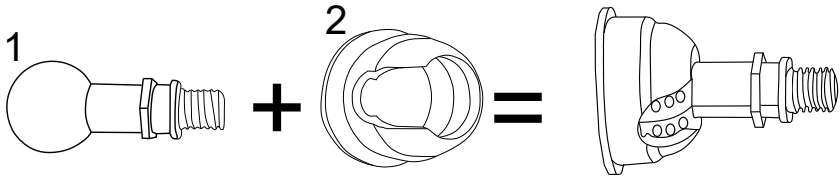

» Pass the ring through the assembly above (piece 3);

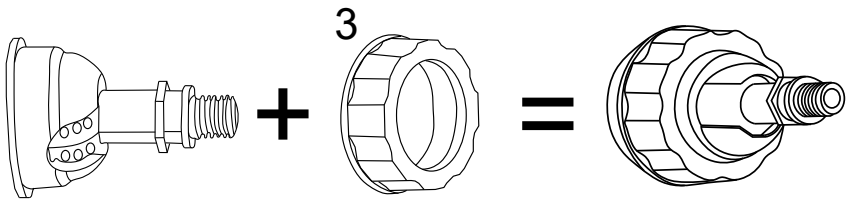

» Screw the ring onto the base of the articulator (piece 4);

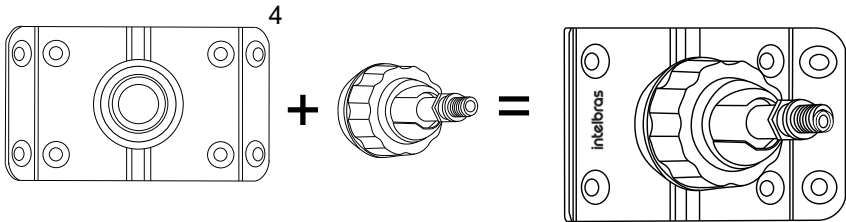

» Remove the plate and make a hole at the indicated location on the base using a drill or whatever tool you deem appropriate, check that the hole made allows the passage of the support shaft. Then, insert the nut in the housing located inside the base;

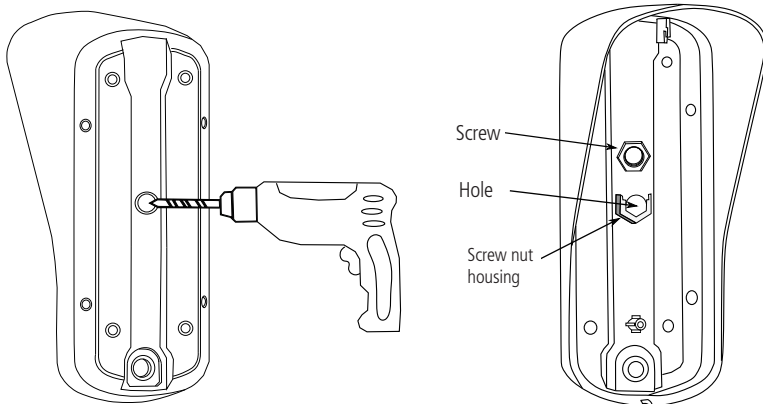

» Insert the shaft through the hole, turning it clockwise.

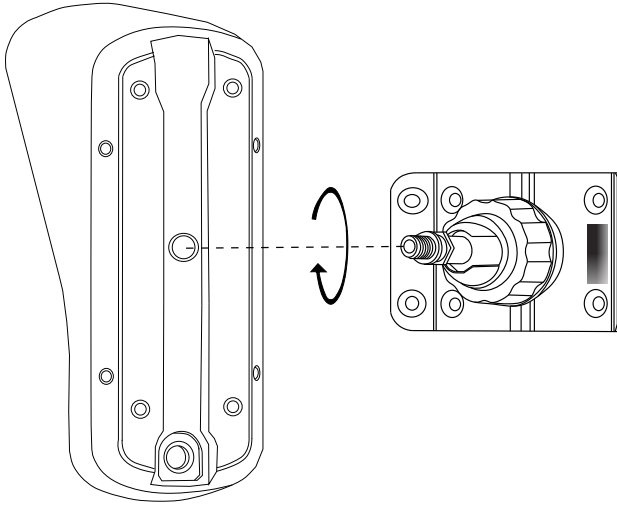

### 11.6. Installation with the base of the IVP 8000 EX without drilling

» Insert the shaft into the cover (piece 1 and piece 2);

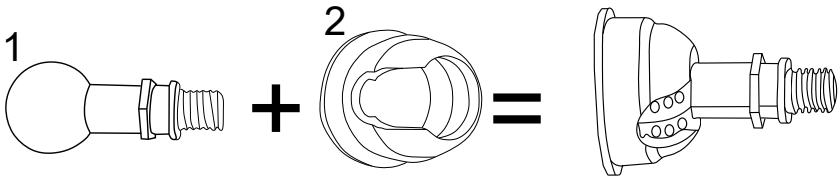

» Pass the ring through the assembly above (piece 3);

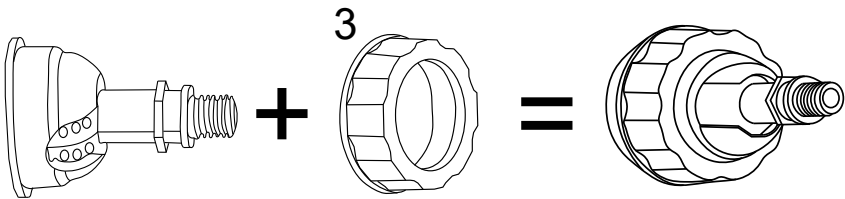

» Insert the nut in the connector (pieces 5 and 6); Installation using the articulator:

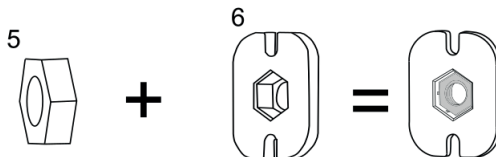

- » Fix the connector on the base of the sensor using the two screws as shown in figure 1, observe the existing hole in the base, then insert the shaft through the hole, rotating it clockwise as shown in figure 2.

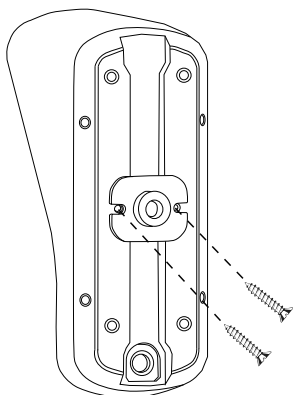

Figure 1

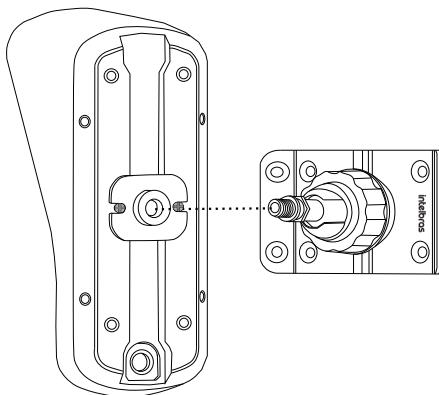
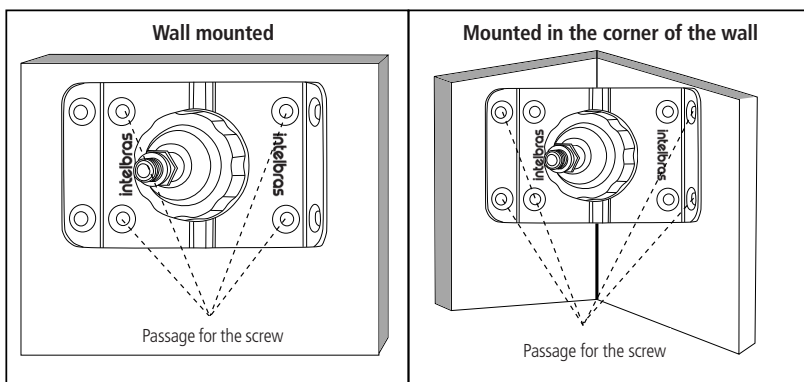
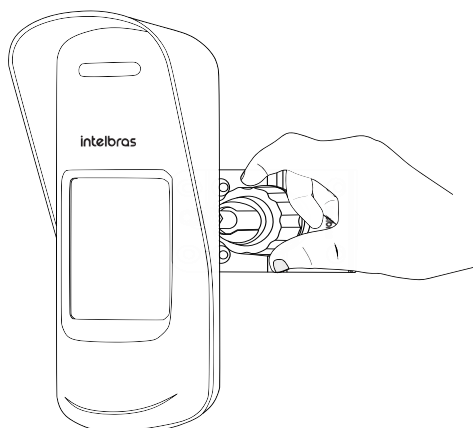

Figure 2

- » If the sensor is installed on a flat surface, use the four innermost holes in the base for mounting. If the sensor is used on a 90° corner, use the four outermost holes on the base;



- » After definitively fixing the base, direct the sensor to the desired detection field, always respecting its specifications. Lock the sensor position by turning the fixing ring clockwise until you feel that it is firm.



## Installation without using the articulator

- » For installation directly on the wall, or in the corner of the wall, remove the plate and break the seals indicated for the holes in the rear fixing cover.



### Attention!

Garanta que a pelagem esteja de acordo com o tamanho da ação, pois uma furação pode ser acionada para o interior do produto.

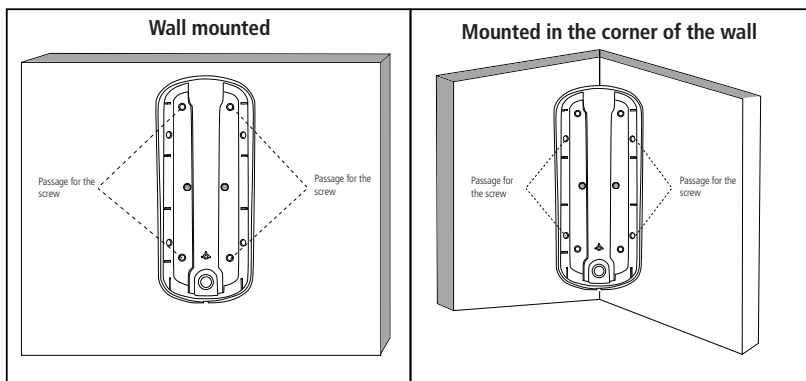



# Warranty term

---

It is expressly stated that this contractual warranty is given subject to the following conditions:

---

Name of customer:

Signature of the customer:

No. of the invoice:

Date of purchase:

Model:

Serial No:

Reseller:

---

1. All parts and components of the product are under warranty against possible manufacturing defects, which may present, for a period of one (1) year, – comprising 90 (ninety) days of legal warranty and 9 (nine) months of contractual warranty, –, counted from the date of purchase of the product by the Consumer, as stated in the invoice of purchase of the product, which is part of this Term throughout the national territory. This contractual warranty includes the express exchange of products that are defective in manufacture. In case no manufacturing defect is found, but flaw(s) from inappropriate use, the Consumer will bear these expenses.
2. Product installation must be done in accordance with the Product Manual and/or Installation Guide. If your product needs to be installed and configured by a qualified technician, look for a suitable and specialized professional, and the costs of these services are not included in the value of the product.
3. If the defect is found, the Consumer should immediately communicate with the nearest Authorized Service listed by the manufacturer, – only they are authorized to examine and remedy the defect during the warranty period provided herein. If this is not respected, this guarantee will lose its validity, as the violation of the product will be characterized.
4. In the event that the Customer request home care, he/she should refer to the nearest Authorized Service for the technical visit fee. If the need for withdrawal of the product is found, the expenses arising, such as transportation and safety to and from the product, are under the responsibility of the Consumer.
5. The warranty will totally lose its validity in the event of any of the following: a) if the defect is not of manufacture, but caused by the Consumer or by third parties alien to the manufacturer; b) if the damage to the product comes from accidents, claims, agents of nature (lightning, floods, landslides, etc. ), humidity, mains voltage (overvoltage caused by accidents or excessive mains fluctuations), installation/use in disagreement with the user manual or due to natural wear of parts and components; c) if the product has been influenced by chemical, electromagnetic, electrical or animal (insects, etc.); d) if the product's serial number has been tampered with or erased; e) if the device has been tampered with.
6. This warranty does not cover loss of data, so it is recommended that the Consumer make a regular backup of the data on the product.
7. Intelbras is not responsible for the installation of this product and also for any attempts of fraud and/or sabotage on its products. Keep software and application updates, if any, up to date, as well as network protections necessary to pro-tect against hackers. The equipment is guaranteed against flaws within its normal conditions of use, and it is important to be aware that, since it is an electronic equipment, it is not free from frauds and scams that may interfere with its correct functioning.
8. This product has an internal battery. After their useful life, the batteries must be delivered to an authorized technical assistance office at Intelbras or directly to the environmentally appropriate final disposal, avoiding environmental impacts and health. If you prefer, the battery, as well as other unused Intelbras electronics, can be disposed of at any Green Electron collection point (electronic waste manager to which we are associated). In case of doubt about the reverse logistics process, please contact us by phone (48) 2106-0006 or 0800 704 2767 (Monday to Friday from 8 am to 8 pm and on Saturdays from 8 am to 6 pm) or through e-mail [suporte@intelbras.com.br](mailto:suporte@intelbras.com.br).

Since these are the conditions of this complementary Warranty Term, Intelbras S/A reserves the right to change the general, technical and aesthetic characteristics of its products without prior notice.

All images in this manual are illustrative.

# intelbras

---



*talk to us*

**Customer Support:** ☎ (48) 2106 0006

**Forum:** [forum.intelbras.com.br](http://forum.intelbras.com.br)

**Support via chat:** [chat.intelbras.com.br](http://chat.intelbras.com.br)

**Support via e-mail:** [suporte@intelbras.com.br](mailto:suporte@intelbras.com.br)

**Customer Service:** 0800 7042767

**Where to buy? Who installs it?** 0800 7245115

Produced by: Intelbras S/A – Indústria de Telecomunicação Eletrônica Brasileira  
Rodovia BR 459, km 124, nº 1325 – Distrito Industrial – Santa Rita do Sapucaí/MG – 37540-000  
CNPJ 82.901.000/0016-03 – [www.intelbras.com.br](http://www.intelbras.com.br)

01.23  
Made in Brazil